



SERVING THE FOOD INDUSTRY SINCE 1951

71" Ice Cream Display Chest Freezer with Flat Glass Top

ITEM: 46730
MODEL: FR-CN-0560-R



Designed to merchandise and provide increased sales of frozen novelties and seasonal specialties.

Flat glass top prominently displays your products, and with space for 12 tubs of ice cream, it is ideal for ice cream shops and supermarkets. Baskets are not limited to carrying tubs of ice cream only, and can be used to store other frozen product.

• **Large Storage**

With 20 cu.ft of internal storage spread over 6 baskets, this unit offers ample space to store a large variety of frozen products.

• **Easy to Move**

Built with 6 casters, 2 with brakes, the unit is easy to move and secure in your business.

• **Sliding Door with Lock**

Classic design with a smooth gliding sliding door, lockable to keep your merchandise secure in the after hours.

• **Flexible Temperature Settings**

Capable of keeping your product at a temperature of -26°C to 4°C, this unit can be used as a refrigerator for non-frozen foods in a pinch.

Telephone: 1-800-465-0234

Fax: (905) 607-0234

Email: sales@omcan.com

Website: www.omcan.com



Authorized Dealer

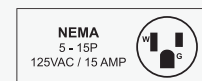

TECHNICAL SPECIFICATION

Item	46730
Model	FR-CN-0560-R
Capacity	20 cu.ft
Doors	2 Sliding Doors
Baskets	6
Basket Capacity	2 x 3 Gallon Tubs or 24kg. ea
Temperature Range	-15°F to 40°F / -26°C to 4°C
Refrigerant	R290
Power	295 W
Amperage	4 A
Electricals	115V / 60 Hz / 1Ph
Compressor	2/3 HP+
Net Dimensions (WDH)	70.9" x 28.14" x 34.4" (1800 x 715 x 875 mm)
Gross Dimensions (WDH)	77" x 36" x 45" (1875 x 760 x 950 mm)
Net Weight	194 lb. (88 kg.)
Gross Weight	240 lb. (108.9 kg.)

TECHNICAL DRAWING

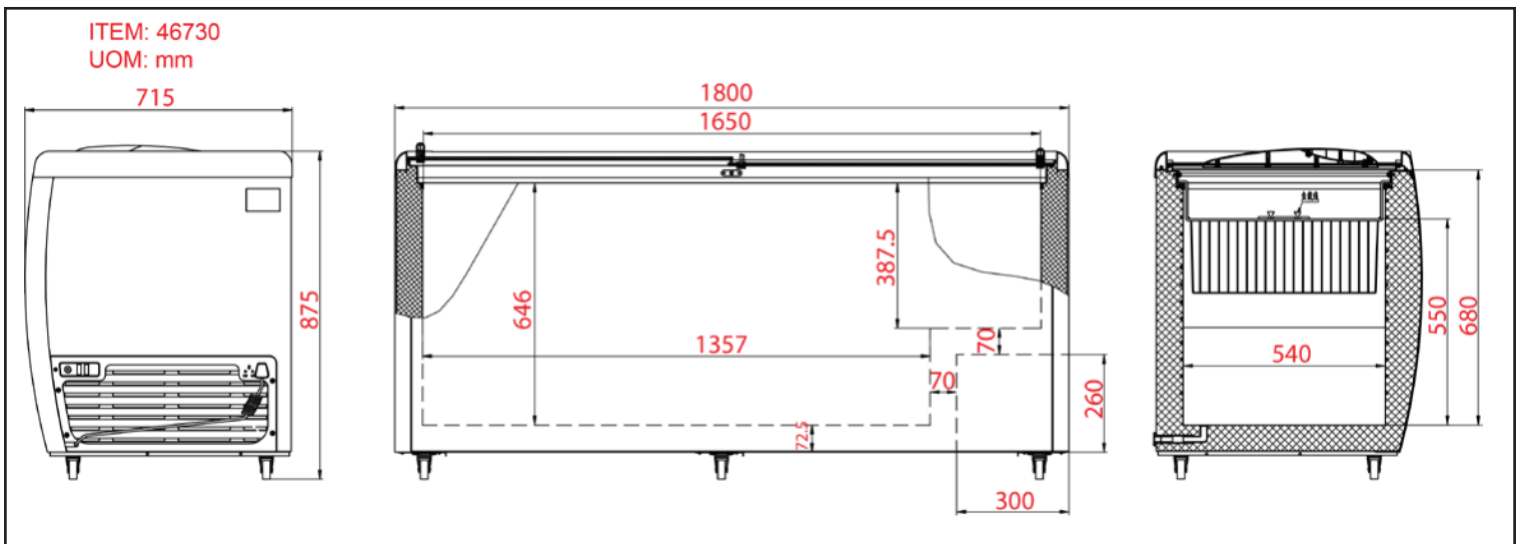

BMAD System (Low maintenance high performance). Dimensions rounded up to the nearest inch or millimeter. Specifications subject to change without notice.